



**PHYSICS.
OLYMPIAD.CH**

PHYSIK-OLYMPIADE
OLYMPIADES DE PHYSIQUE
OLIMPIADI DELLA FISICA

Physics Olympiad

Second Round

17 January 2024

Part 1 : 21 MC questions

Duration : 60 minutes

Total : 21 points (21×1)

Authorized material : Simple calculator

Writing and drawing material

Good luck!

Supported by :



Natural constants

Caesium hyperfine frequency	$\Delta\nu_{\text{Cs}}$	9.192 631 770	$\times 10^9$	s^{-1}
Speed of light in vacuum	c	2.997 924 58	$\times 10^8$	$\text{m} \cdot \text{s}^{-1}$
Planck constant	h	6.626 070 15	$\times 10^{-34}$	$\text{kg} \cdot \text{m}^2 \cdot \text{s}^{-1}$
Elementary charge	e	1.602 176 634	$\times 10^{-19}$	$\text{A} \cdot \text{s}$
Boltzmann constant	k_{B}	1.380 649	$\times 10^{-23}$	$\text{K}^{-1} \cdot \text{kg} \cdot \text{m}^2 \cdot \text{s}^{-2}$
Avogadro constant	N_{A}	6.022 140 76	$\times 10^{23}$	mol^{-1}
Luminous efficacy of radiation	K_{cd}	6.83	$\times 10^2$	$\text{cd} \cdot \text{kg}^{-1} \cdot \text{m}^{-2} \cdot \text{s}^3 \cdot \text{sr}$
Magnetic constant	μ_0	1.256 637 062 12(19)	$\times 10^{-6}$	$\text{A}^{-2} \cdot \text{kg} \cdot \text{m} \cdot \text{s}^{-2}$
Electric constant	ε_0	8.854 187 812 8(13)	$\times 10^{-12}$	$\text{A}^2 \cdot \text{kg}^{-1} \cdot \text{m}^{-3} \cdot \text{s}^4$
Gas constant	R	8.314 462 618...		$\text{K}^{-1} \cdot \text{kg} \cdot \text{m}^2 \cdot \text{mol}^{-1} \cdot \text{s}^{-2}$
Stefan-Boltzmann constant	σ	5.670 374 419...	$\times 10^{-8}$	$\text{K}^{-4} \cdot \text{kg} \cdot \text{s}^{-3}$
Gravitational constant	G	6.674 30(15)	$\times 10^{-11}$	$\text{kg}^{-1} \cdot \text{m}^3 \cdot \text{s}^{-2}$
Electron mass	m_{e}	9.109 383 701 5(28)	$\times 10^{-31}$	kg
Neutron mass	m_{n}	1.674 927 498 04(95)	$\times 10^{-27}$	kg
Proton mass	m_{p}	1.672 621 923 69(51)	$\times 10^{-27}$	kg
Standard acceleration of gravity	g_{n}	9.806 65		$\text{m} \cdot \text{s}^{-2}$

Multiple Choice

Duration: 60 minutes

Marks: 21 points (1 point for each correct answer)

- Multiple-Choice (MC) questions have several statements, of which **exactly one** is correct. If you mark exactly the right answer on the answer sheet, you get one point, otherwise zero.

Question 1.1 (MC)

What is the approximate mass of water contained in Lake Geneva?

- A) 1×10^{12} kg B) 1×10^{14} kg
 C) 1×10^{16} kg D) 1×10^{18} kg

Question 1.2 (MC)

Stars are formed by the gravitational collapse of a gas cloud. The cloud collapses if its radius exceeds a limit called Jeans' length λ . For a cloud of temperature T , density ρ and made of molecules of mass m , how is λ defined?

- A) $\lambda = \sqrt{\frac{15k_B T m \rho}{4\pi G}}$ B) $\lambda = \sqrt{\frac{15k_B m \rho}{4\pi G T}}$
 C) $\lambda = \sqrt{\frac{15k_B T}{4\pi G m \rho}}$ D) $\lambda = \sqrt{\frac{15k_B}{4\pi G T m \rho}}$

Question 1.3 (MC)

Evaluate $\int_0^r \sqrt{r^2 - x^2} dx$ for $r > 0$.

- A) 0 B) $\frac{\pi r^2}{2}$ C) $\frac{r^2}{2}$
 D) $\frac{\pi r^2}{4}$ E) $\frac{r^2}{\sin(1)}$ F) $2\pi r$

Question 1.4 (MC)

Let us consider two vectors \vec{v} and $\vec{\omega}$. The angle between the two vectors is θ , and v and ω are the norms of \vec{v} and $\vec{\omega}$, respectively. What is the norm of $(\vec{v} + \vec{\omega}) \times (\vec{\omega} + \vec{v})$?

- A) 0 B) $v^2 + 2\omega v \sin(\theta) + \omega^2$
 C) $v^2 + 2\omega v + \omega^2$ D) $2\omega v \sin(\theta)$
 E) $2\omega v$ F) $\sin(\theta) (v^2 + 2\omega v + \omega^2)$

Question 1.5 (MC)

Two balls of mass m_a and m_b respectively collide. The balls are restricted to one dimension (meaning that they continue moving along the same axis after the collision). Originally A was moving with velocity \vec{v} and B was at rest. After the collision, A continues moving with a speed of approximately $\|\vec{v}\|$. Which of the following statements can be true? Assume that the balls undergo an elastic collision with no outside forces.

($p \ll q$ ($p \gg q$) means p is much smaller (larger) than q)

I: $m_a = m_b$, II: $m_a \ll m_b$, III: $m_a \gg m_b$

- A) None of them B) Only I
 C) Only II D) Only III
 E) Only II and III F) I, II and III

Question 1.6 (MC)

A geostationary orbit is an orbit that has the same period as the Earth's rotation around its own axis. What is the height h from the ground of a satellite on such an orbit, assuming that the mass of the Earth is $M = 5.97 \times 10^{24}$ kg, that its radius is $R = 6370$ km and that the satellite has mass 600 kg? You can assume a circular orbit.

- A) 720 km B) 36 000 km
 C) 42 000 km D) 87 000 km

Question 1.7 (MC)

Consider a massive planet orbiting a star with an elliptical orbit as shown on the diagram. Assume that this system is isolated and that the only interaction is the gravitational attraction between the star and the planet.

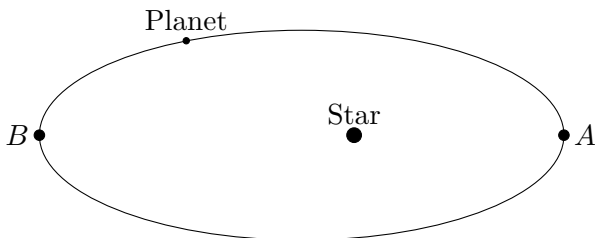

Which of the following statements correctly describes the kinetic energy of the star and the gravitational potential energy of the system when the planet is at point A (K_A, U_A) and point B (K_B, U_B)?

- A) $K_A > K_B$ and $U_A > U_B$
- B) $K_A > K_B$ and $U_A < U_B$
- C) $K_A < K_B$ and $U_A > U_B$
- D) $K_A < K_B$ and $U_A < U_B$
- E) $K_A = K_B$ and $U_A < U_B$
- F) $K_A = K_B$ and $U_A = U_B$

Question 1.8 (MC)

Bob went on a lake in a small boat. For some reason, he took a bowling ball of mass 6 kg and radius 10 cm with him. He is now wondering what would happen to the water level if he was to drop the ball in the lake. The volume of the holes of the bowling ball can be neglected.

- A) The water level would decrease.
- B) The water level would remain the same.
- C) The water level would increase.
- D) Not enough information is given.

Question 1.9 (MC)

Let us consider an inelastic rope of length L attached to two fixed points A and B separated by a distance $D < L$. On this rope we place a pulley that can move freely without friction along the rope and to which we let a mass m hang (similarly to a necklace with a pendant). The rope is assumed to remain taut. Which of the following trajectories can the material point follow?

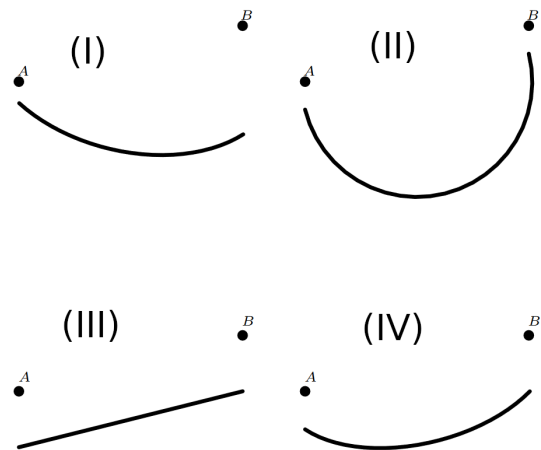

- A) I
- B) II
- C) III
- D) IV

Question 1.10 (MC)

We have two lenses of focal lengths of absolute value 40 mm and 60 mm, respectively. We want to create an afocal system, meaning that parallel rays entering the system also exit it parallel. At which distance from one another should the two lenses be placed to create such a system?

- A) 0 mm
- B) 20 mm
- C) 40 mm
- D) 50 mm
- E) 60 mm
- F) 100 mm
- G) It depends on the lenses.

Question 1.11 (MC)

Square park is a 1000 m by 1000 m recreational area. The northern half is covered with water, the southern half is grassland. Alice is at the south-western corner of the area. She wants to visit her friend Bob, who is at the north-eastern corner. She runs with a speed of $5 \text{ m} \cdot \text{s}^{-1}$ and swims with a speed of $1 \text{ m} \cdot \text{s}^{-1}$. At what angle (clockwise, zero being north) should she start running, if she wants to get there as quickly as possible?

- A) 0° B) 10.10° C) 45°
 D) 61.24° E) 63.43°

Question 1.12 (MC)

Consider a water circulation system consisting of a pipe of length 10 m and a pump. We denote the water flow rate for this system R_0 . When a second pipe of 10 m is added in parallel to the pump (dashed line), the water flow rate through the pump changes to R_1 . What is ratio $\frac{R_1}{R_0}$, assuming that the pumping power remains constant? The pressure loss along the pipe can be approximated to be proportional to the length of the pipe and velocity of the water.

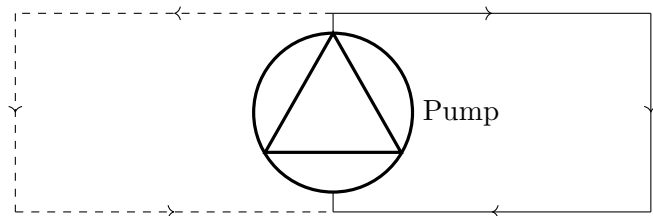

- A) $\frac{1}{2}$ B) $\frac{1}{\sqrt{2}}$ C) $\sqrt{2}$ D) 2

Question 1.13 (MC)

What is the mean absolute value of the speed along the x -axis of particles of mass m in an ideal gas with temperature T ?

- A) $\frac{3}{2}k_B T$ B) $\frac{1}{2}k_B T$ C) $\frac{3k_B T}{m}$
 D) $\frac{k_B T}{m}$ E) $\sqrt{\frac{3k_B T}{m}}$ F) $\sqrt{\frac{k_B T}{m}}$

Question 1.14 (MC)

Which of these diagrams cannot represent a Carnot cycle?

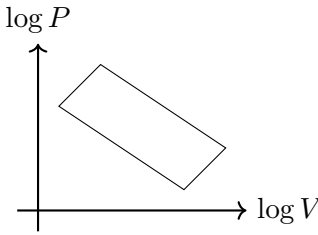
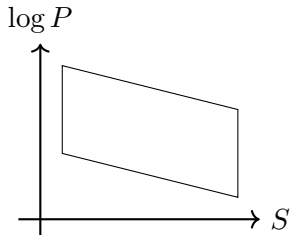
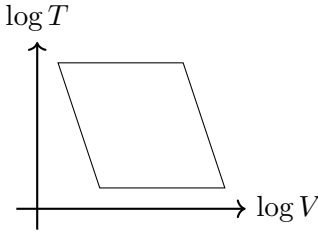
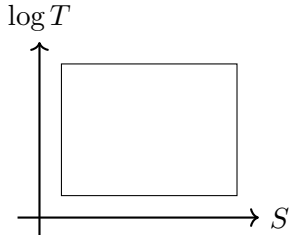
- A)  B) 
 C)  D) 

Question 1.15 (MC)

Consider a copper hollow ball with radius $R > 0$ and finite thickness $0 < d < R$ submerged in water. Initially there are no resultant forces acting on it. The ball is heated up, without changing the temperature of the surrounding water. What accurately describes what will happen (and why)?

- A) The ball will start moving upwards because its mass is decreasing.
 B) The ball will start moving upwards because its volume is increasing.
 C) The ball will start moving downwards because its mass is increasing.
 D) The ball will start moving downwards because its volume is decreasing.
 E) Nothing will happen, the temperature of the ball does not change the forces acting on it.
 F) The ball will start oscillating around its initial position.

Question 1.16 (MC)

Out of the following configurations, which has the greatest value of electric field strength at point P ? Here, the \oplus and \ominus symbols represent point charges of value $+|Q|$ and $-|Q|$, respectively.

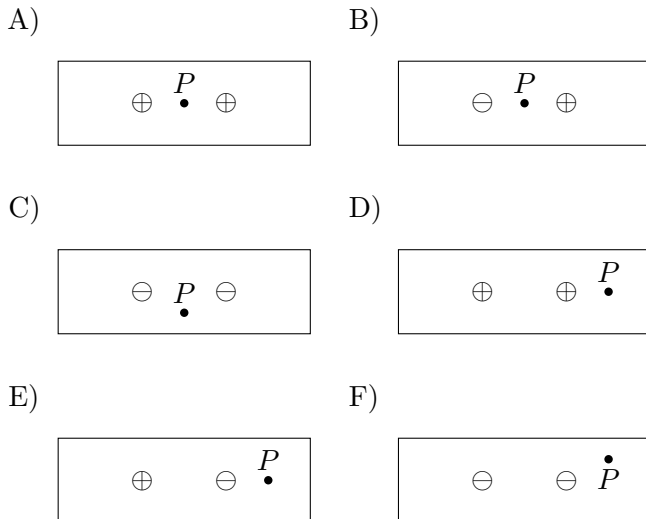

Question 1.17 (MC)

What is the voltage of the battery on the left of the diagram?

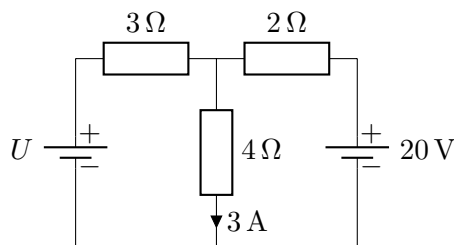

- A) 0 V B) 9 V C) 12 V D) 15 V E) 30 V
- F) This circuit contains a short.

Question 1.18 (MC)

Consider two infinite, positively charged parallel plates of equal charge density. Is the midpoint M between the two plates an equilibrium point? If so, what type of equilibrium is it?

- A) M is not an equilibrium point.
- B) M is a stable equilibrium point.
- C) M is an unstable equilibrium point.
- D) M is a neutral equilibrium point.

Question 1.19 (MC)

A charged particle of mass m and charge q is moving with velocity \vec{v} , parallel to a magnetic field of strength B . What is the acceleration (modulus and direction) of the particle?

- A) 0
- B) Bqv , perpendicular to the velocity
- C) Bqv , parallel to the velocity
- D) $\frac{Bqv}{m}$, perpendicular to the velocity
- E) $\frac{Bqv}{m}$, parallel to the velocity
- F) $\frac{Bq}{m}$, parallel to the magnetic field

Question 1.20 (MC)

A mass is attached to a horizontal spring on a surface without friction. It is displaced a distance 1 m away from its equilibrium position. After being released, it returns to its equilibrium position for the first time after $t = 1$ s. Air resistance is negligible. What was the norm of its acceleration when it was released?

- A) $a = 2\text{m} \cdot \text{s}^{-2}$ B) $a = 2\pi\text{m} \cdot \text{s}^{-2}$
- C) $a = \frac{1}{16}\text{m} \cdot \text{s}^{-2}$ D) $a = \frac{\pi^2}{4}\text{m} \cdot \text{s}^{-2}$
- E) $a = \frac{\pi}{2}\text{m} \cdot \text{s}^{-2}$ F) $a = 4\pi^2\text{m} \cdot \text{s}^{-2}$

Question 1.21 (MC)

You are in a sunlit room, watching a very small dust particle that is suspended in mid-air just in front of a loudspeaker that is playing some very loud music. The loudspeaker is pointing in a horizontal direction. In what way do you see the dust particle moving?



- A) Up and down.
- B) Left and right.
- C) Continuously away from the loudspeaker.
- D) No motion.

Multiple Choice: answer sheet

Indicate your answers in the corresponding boxes on this page.

Last name:	First name:	Total:
-------------------	--------------------	---------------

	A	B	C	D	E	F	G
Question 1.1	<input type="checkbox"/>	<input type="checkbox"/>	<input type="checkbox"/>	<input type="checkbox"/>			
Question 1.2	<input type="checkbox"/>	<input type="checkbox"/>	<input type="checkbox"/>	<input type="checkbox"/>			
Question 1.3	<input type="checkbox"/>	<input type="checkbox"/>	<input type="checkbox"/>	<input type="checkbox"/>	<input type="checkbox"/>	<input type="checkbox"/>	
Question 1.4	<input type="checkbox"/>	<input type="checkbox"/>	<input type="checkbox"/>	<input type="checkbox"/>	<input type="checkbox"/>	<input type="checkbox"/>	
Question 1.5	<input type="checkbox"/>	<input type="checkbox"/>	<input type="checkbox"/>	<input type="checkbox"/>	<input type="checkbox"/>	<input type="checkbox"/>	
Question 1.6	<input type="checkbox"/>	<input type="checkbox"/>	<input type="checkbox"/>	<input type="checkbox"/>			
Question 1.7	<input type="checkbox"/>	<input type="checkbox"/>	<input type="checkbox"/>	<input type="checkbox"/>	<input type="checkbox"/>	<input type="checkbox"/>	
Question 1.8	<input type="checkbox"/>	<input type="checkbox"/>	<input type="checkbox"/>	<input type="checkbox"/>			
Question 1.9	<input type="checkbox"/>	<input type="checkbox"/>	<input type="checkbox"/>	<input type="checkbox"/>			
Question 1.10	<input type="checkbox"/>	<input type="checkbox"/>	<input type="checkbox"/>	<input type="checkbox"/>	<input type="checkbox"/>	<input type="checkbox"/>	<input type="checkbox"/>
Question 1.11	<input type="checkbox"/>	<input type="checkbox"/>	<input type="checkbox"/>	<input type="checkbox"/>	<input type="checkbox"/>		
Question 1.12	<input type="checkbox"/>	<input type="checkbox"/>	<input type="checkbox"/>	<input type="checkbox"/>			
Question 1.13	<input type="checkbox"/>	<input type="checkbox"/>	<input type="checkbox"/>	<input type="checkbox"/>	<input type="checkbox"/>	<input type="checkbox"/>	
Question 1.14	<input type="checkbox"/>	<input type="checkbox"/>	<input type="checkbox"/>	<input type="checkbox"/>			
Question 1.15	<input type="checkbox"/>	<input type="checkbox"/>	<input type="checkbox"/>	<input type="checkbox"/>	<input type="checkbox"/>	<input type="checkbox"/>	
Question 1.16	<input type="checkbox"/>	<input type="checkbox"/>	<input type="checkbox"/>	<input type="checkbox"/>	<input type="checkbox"/>	<input type="checkbox"/>	
Question 1.17	<input type="checkbox"/>	<input type="checkbox"/>	<input type="checkbox"/>	<input type="checkbox"/>	<input type="checkbox"/>	<input type="checkbox"/>	
Question 1.18	<input type="checkbox"/>	<input type="checkbox"/>	<input type="checkbox"/>	<input type="checkbox"/>			
Question 1.19	<input type="checkbox"/>	<input type="checkbox"/>	<input type="checkbox"/>	<input type="checkbox"/>	<input type="checkbox"/>	<input type="checkbox"/>	
Question 1.20	<input type="checkbox"/>	<input type="checkbox"/>	<input type="checkbox"/>	<input type="checkbox"/>	<input type="checkbox"/>	<input type="checkbox"/>	
Question 1.21	<input type="checkbox"/>	<input type="checkbox"/>	<input type="checkbox"/>	<input type="checkbox"/>			

Multiple Choice: solutions

	A	B	C	D	E	F	G
Question 1.1	<input type="checkbox"/>	<input checked="" type="checkbox"/>	<input type="checkbox"/>	<input type="checkbox"/>			
Question 1.2	<input type="checkbox"/>	<input type="checkbox"/>	<input checked="" type="checkbox"/>	<input type="checkbox"/>			
Question 1.3	<input type="checkbox"/>	<input type="checkbox"/>	<input type="checkbox"/>	<input checked="" type="checkbox"/>	<input type="checkbox"/>	<input type="checkbox"/>	
Question 1.4	<input checked="" type="checkbox"/>	<input type="checkbox"/>	<input type="checkbox"/>	<input type="checkbox"/>	<input type="checkbox"/>	<input type="checkbox"/>	
Question 1.5	<input type="checkbox"/>	<input type="checkbox"/>	<input type="checkbox"/>	<input type="checkbox"/>	<input checked="" type="checkbox"/>	<input type="checkbox"/>	
Question 1.6	<input type="checkbox"/>	<input checked="" type="checkbox"/>	<input type="checkbox"/>	<input type="checkbox"/>			
Question 1.7	<input type="checkbox"/>	<input checked="" type="checkbox"/>	<input type="checkbox"/>	<input type="checkbox"/>	<input type="checkbox"/>	<input type="checkbox"/>	
Question 1.8	<input checked="" type="checkbox"/>	<input type="checkbox"/>	<input type="checkbox"/>	<input type="checkbox"/>			
Question 1.9	<input type="checkbox"/>	<input type="checkbox"/>	<input type="checkbox"/>	<input checked="" type="checkbox"/>			
Question 1.10	<input type="checkbox"/>	<input type="checkbox"/>	<input type="checkbox"/>	<input type="checkbox"/>	<input type="checkbox"/>	<input type="checkbox"/>	<input checked="" type="checkbox"/>
Question 1.11	<input type="checkbox"/>	<input type="checkbox"/>	<input type="checkbox"/>	<input checked="" type="checkbox"/>	<input type="checkbox"/>		
Question 1.12	<input type="checkbox"/>	<input type="checkbox"/>	<input checked="" type="checkbox"/>	<input type="checkbox"/>			
Question 1.13	<input type="checkbox"/>	<input type="checkbox"/>	<input type="checkbox"/>	<input type="checkbox"/>	<input type="checkbox"/>	<input checked="" type="checkbox"/>	
Question 1.14	<input checked="" type="checkbox"/>	<input type="checkbox"/>	<input type="checkbox"/>	<input type="checkbox"/>			
Question 1.15	<input type="checkbox"/>	<input checked="" type="checkbox"/>	<input type="checkbox"/>	<input type="checkbox"/>	<input type="checkbox"/>	<input type="checkbox"/>	
Question 1.16	<input type="checkbox"/>	<input checked="" type="checkbox"/>	<input type="checkbox"/>	<input type="checkbox"/>	<input type="checkbox"/>	<input type="checkbox"/>	
Question 1.17	<input type="checkbox"/>	<input checked="" type="checkbox"/>	<input type="checkbox"/>	<input type="checkbox"/>	<input type="checkbox"/>	<input type="checkbox"/>	
Question 1.18	<input type="checkbox"/>	<input type="checkbox"/>	<input type="checkbox"/>	<input checked="" type="checkbox"/>			
Question 1.19	<input checked="" type="checkbox"/>	<input type="checkbox"/>	<input type="checkbox"/>	<input type="checkbox"/>	<input type="checkbox"/>	<input type="checkbox"/>	
Question 1.20	<input type="checkbox"/>	<input type="checkbox"/>	<input type="checkbox"/>	<input checked="" type="checkbox"/>	<input type="checkbox"/>	<input type="checkbox"/>	
Question 1.21	<input type="checkbox"/>	<input checked="" type="checkbox"/>	<input type="checkbox"/>	<input type="checkbox"/>			



**PHYSICS.
OLYMPIAD.CH**

PHYSIK-OLYMPIADE
OLYMPIADES DE PHYSIQUE
OLIMPIADI DELLA FISICA

Physics Olympiad

Second Round

17 January 2024

Part 2 : 3 long problems

Duration : 120 minutes

Total : 48 points (3×16)

Authorized material : Simple calculator

Writing and drawing material

Good luck!

Supported by :



Natural constants

Caesium hyperfine frequency	$\Delta\nu_{\text{Cs}}$	9.192 631 770	$\times 10^9$	s^{-1}
Speed of light in vacuum	c	2.997 924 58	$\times 10^8$	$\text{m} \cdot \text{s}^{-1}$
Planck constant	h	6.626 070 15	$\times 10^{-34}$	$\text{kg} \cdot \text{m}^2 \cdot \text{s}^{-1}$
Elementary charge	e	1.602 176 634	$\times 10^{-19}$	$\text{A} \cdot \text{s}$
Boltzmann constant	k_{B}	1.380 649	$\times 10^{-23}$	$\text{K}^{-1} \cdot \text{kg} \cdot \text{m}^2 \cdot \text{s}^{-2}$
Avogadro constant	N_{A}	6.022 140 76	$\times 10^{23}$	mol^{-1}
Luminous efficacy of radiation	K_{cd}	6.83	$\times 10^2$	$\text{cd} \cdot \text{kg}^{-1} \cdot \text{m}^{-2} \cdot \text{s}^3 \cdot \text{sr}$
Magnetic constant	μ_0	1.256 637 062 12(19)	$\times 10^{-6}$	$\text{A}^{-2} \cdot \text{kg} \cdot \text{m} \cdot \text{s}^{-2}$
Electric constant	ε_0	8.854 187 812 8(13)	$\times 10^{-12}$	$\text{A}^2 \cdot \text{kg}^{-1} \cdot \text{m}^{-3} \cdot \text{s}^4$
Gas constant	R	8.314 462 618...		$\text{K}^{-1} \cdot \text{kg} \cdot \text{m}^2 \cdot \text{mol}^{-1} \cdot \text{s}^{-2}$
Stefan-Boltzmann constant	σ	5.670 374 419...	$\times 10^{-8}$	$\text{K}^{-4} \cdot \text{kg} \cdot \text{s}^{-3}$
Gravitational constant	G	6.674 30(15)	$\times 10^{-11}$	$\text{kg}^{-1} \cdot \text{m}^3 \cdot \text{s}^{-2}$
Electron mass	m_{e}	9.109 383 701 5(28)	$\times 10^{-31}$	kg
Neutron mass	m_{n}	1.674 927 498 04(95)	$\times 10^{-27}$	kg
Proton mass	m_{p}	1.672 621 923 69(51)	$\times 10^{-27}$	kg
Standard acceleration of gravity	g_{n}	9.806 65		$\text{m} \cdot \text{s}^{-2}$

Long problems

Duration: 120 minutes

Marks: 48 points (3×16)

Start each problem on a new sheet in order to ease the correction.

General hint: The problems consist of partially independent problem parts, so if you get stuck, it is a good idea to read further ahead and to continue with an easier part.

Long problem 2.1: Egg stability (16 points)

Let us consider an egg represented by a homogeneous solid of revolution with profile $f(x) = \frac{1}{2}\sqrt{x-x^4}$ on the domain $x \in [a=0, b=1]$. The units of length are arbitrary.

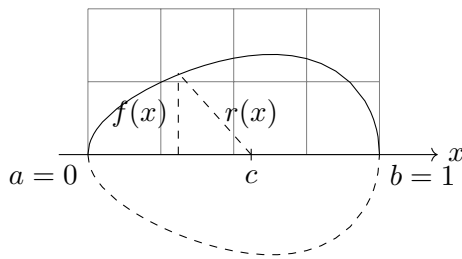

Part A. Centre of gravity and radius (4.5 points)

The centre of gravity c of a solid of revolution lies on its axis and can be calculated by dividing it into discs of infinitesimal thickness dx and volume $\pi f^2(x) dx$:

$$c = \frac{1}{V} \int_a^b x \pi f^2(x) dx,$$

where V is the volume of the solid.

- i. (3 pts) Calculate c for the egg.
- ii. (0.5 pts) If a factor other than $\frac{1}{2}$ had been chosen in the egg's $f(x)$ profile, what would have been the impact on the value of c ? Justify.
- iii. (1 pt) Find an expression for the "radius" $r(x)$ of the egg, i.e. the distance between the centre of gravity and a point $(x, f(x))$ on the surface of the egg. The result should be of the form $\sqrt{P(x)}$, where $P(x)$ is a polynomial.

Part B. Analytical interlude (3 points)

Let $g(x) > 0$ be a strictly positive differentiable function.

- i. (2 pts) Expand $\frac{d\sqrt{g(x)}}{dx}$, the derivative of the square root of $g(x)$.

- ii. (1 pt) Show that the sign of $\frac{d\sqrt{g(x)}}{dx}$ is always equal to that of $\frac{dg(x)}{dx}$.

Part C. Stability of the laid egg (8.5 points)

We now place the egg on a horizontal surface and identify the point where the egg is in contact with the surface by its x coordinate.

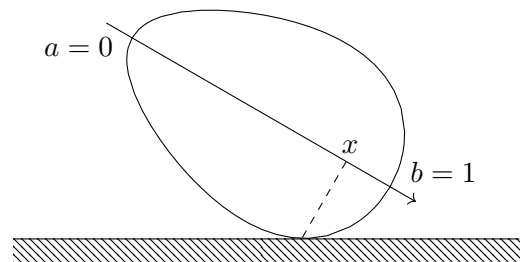

- i. (2 pts) The positions $a = 0$ and $b = 1$ are equilibrium positions, due to the symmetry of revolution. Determine the stability of these two positions from the expression $r(x)$ found in A.iii. and using the result shown in B.ii.

There is a position $a < s < b$ where the egg lying on its side is in stable equilibrium.

- ii. (1 pt) What is the peculiarity of $r(s)$?
- iii. (1.5 pts) Find a polynomial equation for s .
Unfortunately, this polynomial equation is not (easily) solvable. So we are going to look for an approximation using a Taylor expansion.
- iv. (1 pt) Choose a good starting point t for the development. Justify your choice.

- v. (2 pts) Expand the polynomial equation around the chosen t to first order to obtain an affine equation.

- vi. (1 pt) Find the solution \tilde{s} to this new equation and calculate $r(\tilde{s})$ as well.

Long problem 2.2: Clément-Desormes experiment (16 points)

The Clément-Desormes experiment is a thermodynamics experiment used to determine the adiabatic index $\gamma = \frac{C_P}{C_V}$ of an ideal gas, where C_P and C_V are the heat capacities at constant pressure and constant volume, respectively. It consists of a container filled with the studied gas connected to a valve, a manometer (e.g. a mercury manometer) and a pump, see the figure. The three steps of the experiment consist of first increasing the pressure of the gas with the pump, then releasing the excess pressure through the valve and finally waiting for the gas to thermalize. In the following, we will consider the system that contains the n moles of gas remaining in the container after the pressure release (initially, there is more gas in the container than n moles).

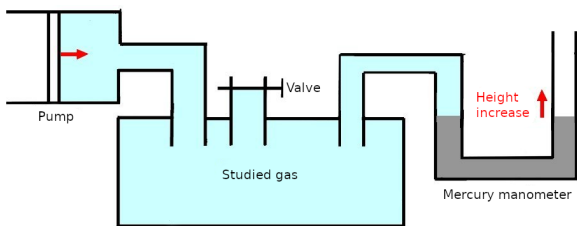

Figure 1: Schematic representation of the Clément-Desormes experiment.

Part A. Mercury manometers (2.25 points)

A mercury manometer uses changes in the height of a column of mercury to determine the pressure of a gas, see the figure. Correspondingly, a millimeter of mercury, denoted mmHg, has become a unit of pressure. It is defined as the hydrostatic pressure generated by a column of mercury one millimeter high at a temperature of 0°C .

- i. (0.5 pts)** What is the hydrostatic pressure of a column of fluid of density ρ and height h ?
- ii. (0.75 pts)** How is 1 bar expressed in mmHg? The density of mercury at ambient pressure and temperature $T = 0^\circ\text{C}$ is $13.595\text{ g} \cdot \text{cm}^{-3}$.
- iii. (1 pt)** Why is mercury particularly convenient to build such manometers as compared to other liquids?

Part B. Pumping and releasing (2 points)

One first uses the pump to increase the gas pressure to get from (P_0, V_0) to (P_A, V_{tot}) isothermally, where $P_A = P_0 + h_A = 780.31\text{ mmHg}$ and V_{tot} is the total volume of the gas container assumed to remain fixed for the rest of the experiment. The (partial) volume of the n moles at this stage is $V_A < V_{\text{tot}}$. So, at this point we have pressure and volume (P_A, V_A) for the n moles of gas considered. One then quickly opens the valve to let some of the gas escape and cancel the overpressure, and closes the valve directly after. The manometer tube is arbitrarily thin so the volume change necessary to modify the mercury height is negligible. We are only left with our n moles of gas with pressure and volume $(P_B, V_B) = (P_0, V_{\text{tot}})$. The ambient temperature is $T_0 = 12.5^\circ\text{C}$ and the ambient pressure is $P_0 = 766.50\text{ mmHg}$.

- i. (0.5 pts)** What type of thermodynamic process happens between the situations $A = (P_A, V_A)$ and $B = (P_B, V_B)$? Why?
- ii. (1.5 pts)** For such a process, what equation relates the pressure and volume in situations A and B ?

Part C. Back to thermal equilibrium (2.5 points)

After a while, the systems reaches again thermal equilibrium with respect to the exterior. One ends up with pressure and volume $(P_C, V_C) = (P_0 + h_C, V_{\text{tot}})$, with $h_C = 3.61\text{ mmHg}$.

- i. (0.5 pts)** What type of thermodynamic process happens between the situations B and $C = (P_C, V_C)$? Why?
- ii. (0.5 pts)** What is the temperature T_C in situation C ?
- iii. (1.5 pts)** With what equation can one relate the pressure and volume in situations A and C ?

Part D. Finding the adiabatic index (9.25 points)

We can now consider the overall process to determine the adiabatic index γ from the previous measurements and results.

- i. (1.25 pts)** Draw schematically in a P - V diagram the thermodynamic processes acting on our system of n moles from step A to C .

ii. (2 pts) Use your equations from the previous parts to express $\frac{P_0+h_A}{P_0}$ as a function of (and including all) P_0 , h_A , h_C and γ .

iii. (2.5 pts) Noticing that $h_A \ll P_0$ and $h_C \ll P_0$ (\ll means “much smaller than”), simplify your expression for $\frac{P_0+h_A}{P_0}$.

Hint: for $x \ll 1$, one can approximate $(1+x)^\alpha \approx 1 + \alpha x$.

Hint: you can neglect $\left(\frac{h_A}{P_0}\right)^2$, $\left(\frac{h_C}{P_0}\right)^2$, $\frac{h_A h_C}{P_0^2}$ and higher order terms.

iv. (1 pt) Using your previous results, express the adiabatic index γ as a function of h_A and h_C .

v. (1 pt) Compute numerically the adiabatic index γ from the given measurements.

vi. (1 pt) From the equipartition theorem, it is possible to derive that $C_V = \frac{f}{2}R$ and $C_P = \frac{f+2}{2}R$, where f is the number of degrees of freedom allowed for the gas molecules. The gas studied here has $f = 5$ degrees of freedom. What is the relative difference between the theoretical and the experimental values of the adiabatic index γ ?

vii. (0.5 pts) What could be possible reasons for this difference?

Long problem 2.3: Mirror charges (16 points)

A very common problem in electrostatics is to determine the electric potential of a system composed of point charges and conductors of various shapes. In this exercise, we will develop a trick, the so-called method of mirror charges or method of images, to greatly simplify such problems in cases with appropriate symmetry. We consider the SI unit system in this exercise.

Part A. Electric potential and conductors (2.25 points)

In this first part, we will discuss Faraday cages.

- i. (0.25 pts)** Write down the electric potential V due to a point charge q as a function of the distance r from the charge.
- ii. (0.5 pts)** Write down the electric potential V due to N point charges q_i , $i \in 1, 2, \dots, N$, as a function of the distances r_i from each charge q_i .
- iii. (0.5 pts)** Consider the situation shown in Fig. B.1. What can you say about the electric potential on the surface of the grounded conducting material?
- iv. (1 pt)** During a storm, is it safer to stay in one's car or outside? Why? Argue using the answer to the previous question.

Part B. Plane mirror charge (4.25 points)

Consider again the situation illustrated in Fig. B.1. The goal of this part is to determine the electric potential at any point above the plane. For this, a trick can be used to simplify the situation considerably. The idea is to introduce an imaginary "mirror" charge in order to reproduce the boundary conditions set by the conducting material.

In electrostatics, if two physical systems have potentials with the same boundary conditions, then both situations are physically equivalent.

So, in order to determine the electric potential of this system, we would like to find another easier system to describe its potential.

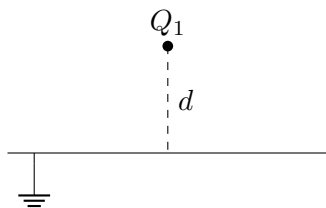

Figure B.1: Infinitely long grounded conductive plane and a charge Q_1 at a position $\vec{r}_1 = (x_1, y_1, z_1) = (0, 0, d)$.

i. (0.25 pts) What are the boundary conditions for the electrostatic potential V of this system?

ii. (1.5 pts) Let us imagine a second physical system with the same charge Q_1 at the same position \vec{r}_1 as in Fig. B.1 but without the conducting plane. Our goal is to find a configuration with a second charge Q_2 at position \vec{r}_2 that has the same boundary conditions as in Fig. B.1. What should Q_2 and $\vec{r}_2 = (x_2, y_2, z_2)$ be for this to happen? Why?

iii. (1 pt) Using your previous results, compute the electric potential $V(x, y, z)$ above the ground plane in the system of Fig. B.1 as a function of the coordinates (x, y, z) , the distance d and the charge Q_1 . The expression can be left as a sum of two terms, it does not have to be fully simplified.

iv. (1.5 pts) Draw schematically the field lines of the system as shown in Fig. B.1, consisting of the point charge and ground plane system, assuming that $Q_1 > 0$ (in a separate sketch, not on the problem sheet).

Part C. Right angle mirror charges (5.5 points)

We will now consider more complex conductor geometries.

i. (2.5 pts) Let us consider the system shown in Fig. C.1. What is the number N of mirror charges needed to reproduce the conductor boundary conditions? What are their values Q_i and their positions $\vec{r}_i = (x_i, y_i, z_i)$ for $i = 1, 2, \dots, N$? Why?

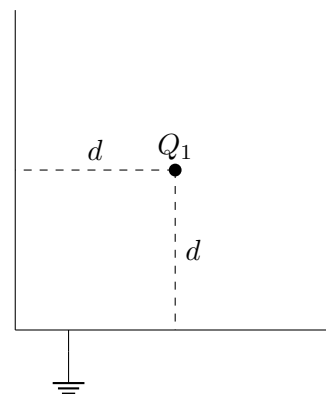

Figure C.1: Two infinitely long grounded half-plane conductors at a right-angle and a charge Q_1 at the position $\vec{r}_1 = (x_1, y_1, z_1) = (d, 0, d)$.

ii. (1 pt) What is the corresponding potential $V(x, y, z)$ as a function of the coordinates (x, y, z) , the distance d and the charge Q_1 ? The expression can be left as a sum of N terms, it does not have to be fully simplified.

iii. (2 pts) Draw schematically the field lines of the charge-half-plane conductors system, assuming that $Q_1 < 0$ (in a separate sketch, not on the problem sheet).

Part D. Circular mirror charges (4 points)

It is also possible to define mirror charges for curved geometries.

i. (2.5 pts) Let us now consider the system shown in Fig. D.1. It turns out that only one mirror charge is needed to reproduce the corresponding boundary conditions. What is its value Q_2 and position $\vec{r}_2 = (x_2, y_2, z_2)$?

Hint: you are allowed to use without proof that a potential satisfying the appropriate boundary conditions at the positions $(r, 0, 0)$ and $(-r, 0, 0)$ satisfies the boundary conditions on the whole sphere.

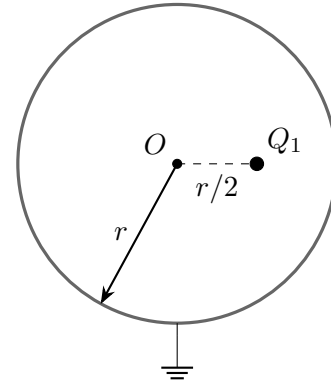

Figure D.1: Spherical grounded conductor of radius r with centre O at position $\vec{r}_0 = (0, 0, 0)$ and charge Q_1 at position $\vec{r}_1 = (x_1, y_1, z_1) = (r/2, 0, 0)$. We see here a slice at $y = 0$ of the sphere in the xz -plane.

ii. (1.5 pts) What is the corresponding potential $V(x, y, z)$ as a function of the coordinates (x, y, z) , the radius r and the charge Q_1 ? The expression can be left as a sum of two terms, it does not have to be fully simplified.

Long problems: solutions

Long problem 2.1: Egg stability

16

Let us consider an egg represented by a homogeneous solid of revolution with profile $f(x) = \frac{1}{2}\sqrt{x-x^4}$ on the domain $x \in [a=0, b=1]$. The units of length are arbitrary.

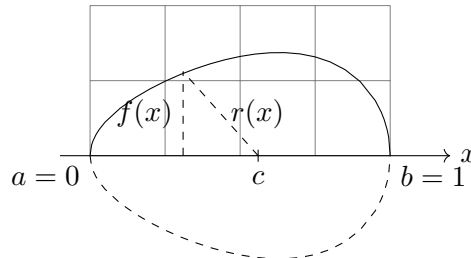

Part A. Centre of gravity and radius

4.5

The centre of gravity c of a solid of revolution lies on its axis and can be calculated by dividing it into discs of infinitesimal thickness dx and volume $\pi f^2(x) dx$:

$$c = \frac{1}{V} \int_a^b x \pi f^2(x) dx,$$

where V is the volume of the solid.

i. Calculate c for the egg.

3

Following the idea of splitting the egg into disk-shaped infinitely thin slices, the volume is given by:

$$V = \int_a^b \pi f^2(x) dx.$$

Thus for the egg, we have

$$c = \frac{\int_0^1 x \frac{1}{4} (x - x^4) dx}{\int_0^1 \frac{1}{4} (x - x^4) dx} = \frac{\int_0^1 (x^2 - x^5) dx}{\int_0^1 (x - x^4) dx} = \frac{[\frac{1}{3}x^3 - \frac{1}{6}x^6]_0^1}{[\frac{1}{2}x^2 - \frac{1}{5}x^5]_0^1},$$

And finally

$$c = \frac{\frac{1}{3} - \frac{1}{6}}{\frac{1}{2} - \frac{1}{5}} = \frac{\frac{1}{6}}{\frac{3}{10}} = \frac{5}{9}.$$

ii. If a factor other than $\frac{1}{2}$ had been chosen in the egg's $f(x)$ profile, what would have been the impact on the value of c ? Justify.

0.5

c wouldn't change, because the factor (squared) appears both in the numerator and in the denominator of c .

0.5

This is the same reason why the egg's density doesn't play a role, nor does π .

iii. Find an expression for the “radius” $r(x)$ of the egg, i.e. the distance between the centre of gravity and a point $(x, f(x))$ on the surface of the egg. The result should be of the form $\sqrt{P(x)}$, where $P(x)$ is a polynomial.

1

We can use the Pythagorean theorem:

$$r(x) = \sqrt{f^2(x) + (x - c)^2},$$

0.5

and we get

$$r(x) = \sqrt{\frac{1}{4}x - \frac{1}{4}x^4 + x^2 + c^2 - 2xc} = \sqrt{-\frac{1}{4}x^4 + x^2 - \frac{31}{36}x + \frac{25}{81}}.$$

0.5

Part B. Analytical interlude

3

Let $g(x) > 0$ be a strictly positive differentiable function.

i. Expand $\frac{d\sqrt{g(x)}}{dx}$, the derivative of the square root of $g(x)$.

2

We can use the generic formula

$$\frac{dg^n(x)}{dx} = ng^{n-1}(x) \frac{dg(x)}{dx}.$$

1

Here we have the case $n = \frac{1}{2}$, so

$$\frac{d\sqrt{g(x)}}{dx} = \frac{1}{2\sqrt{g(x)}} \frac{dg(x)}{dx}.$$

1

Full points are given as long as the answer is of the desired final form, even if the generic formula is not explicitly stated.

ii. Show that the sign of $\frac{d\sqrt{g(x)}}{dx}$ is always equal to that of $\frac{dg(x)}{dx}$.

1

$$g(x) > 0 \Rightarrow \sqrt{g(x)} > 0 \Rightarrow \frac{1}{2\sqrt{g(x)}} > 0.$$

0.5

Thus the factor in front of the derivative does not change the sign, so both will always be equal. This is in particular valid for the case 0: if the derivative of $g(x)$ is null, so is the derivative of $\sqrt{g(x)}$.

0.5

Part C. Stability of the laid egg

8.5

We now place the egg on a horizontal surface and identify the point where the egg is in contact with the surface by its x coordinate.

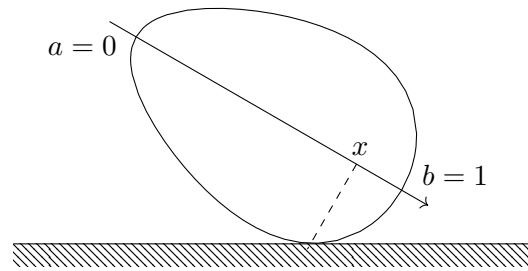

i. The positions $a = 0$ and $b = 1$ are equilibrium positions, due to the symmetry of revolution. Determine the stability of these two positions from the expression $r(x)$ found in A.iii. and using the result shown in B.ii.

2

To study the stability, we need to compute the derivative of the radius found in A.iii. But we are only interested in its sign, so instead, and according to B.ii., we can compute the derivative of its square, $P(x)$.

0.5

$$\frac{dP(x)}{dx} = -x^3 + 2x - \frac{31}{36}.$$

0.5

For $x = a = 0$, $\left. \frac{dP(x)}{dx} \right|_a = -\frac{31}{36} < 0$.

This means that all values slightly larger than a lead to a smaller r^2 , thus also to a smaller r . Because a is at the end of the domain, it corresponds to a local maximum of the radius, and therefore a is an instable equilibrium.

0.5

For $x = b = 1$, $\left. \frac{dP(x)}{dx} \right|_b = -1 + 2 - \frac{31}{36} = \frac{5}{36} > 0$.

This means that all values slightly smaller than b lead again to a smaller r^2 , thus also to a smaller r . Because b is at the other end of the domain, it corresponds to a local maximum of the radius, and therefore b is an instable equilibrium as well.

0.5

There is a position $a < s < b$ where the egg lying on its side is in stable equilibrium.

ii. What is the peculiarity of $r(s)$?

1

It is a local minimum of $r(x)$, and in fact its only minimum.

1

Give 0.5 point if it is only mentioned that the segment of $r(s)$ is perpendicular to the egg's surface.

iii. Find a polynomial equation for s .

1.5

The condition for s is that the derivative of the radius is zero.

0.5

Again we can use B.ii. and only consider the derivative of $P(x)$.

0.5

Thus the equation is

$$-s^3 + 2s - \frac{31}{36} = 0.$$

0.5

Unfortunately, this polynomial equation is not (easily) solvable. So we are going to look for an approximation using a Taylor expansion.

iv. Choose a good starting point t for the development. Justify your choice. **1**

If the egg was symmetric, that is an ellipse, s would be in the center ($\frac{1}{2}$). 0.5

The egg is not very dissymmetric, so $t = \frac{1}{2}$ is a good starting point, and easy to compute with. 0.5

Valid but less justifiable points include $t = c$ (but due to the slope of $f(x)$ in the middle portion of the egg, it should be clear that $t < c$) and $t = 1 - c$. Those are awarded 0.5 points and no double penalty in the subsequent questions.

v. Expand the polynomial equation around the chosen t to first order to obtain an affine equation. **2**

At order zero, we have (remember that we are working with the derivative of $P(x)$)

$$\left. \frac{dP(x)}{dx} \right|_t = -\left(\frac{1}{2}\right)^3 + 2\frac{1}{2} - \frac{31}{36} = -\frac{1}{8} + 1 - \frac{31}{36} = \frac{1}{72}.$$
0.5

At order one, we have

$$\left. \frac{d^2P(x)}{dx^2} \right|_t = -3\left(\frac{1}{2}\right)^2 + 2 = -\frac{3}{4} + 2 = \frac{5}{4}.$$
0.5

Therefore the equation becomes

$$\frac{1}{72} + \frac{5}{4}(x - t) = 0.$$
0.5

And finally

$$\frac{5}{4}x - \frac{11}{18} = 0.$$
0.5

For $t = c$, this gives $\frac{87}{81}x - \frac{1511}{2916} = 0$.

For $t = 1 - c$, this gives $\frac{114}{81}x - \frac{1999}{2916} = 0$.

The equation's factors are not required to be fully simplified.

vi. Find the solution \tilde{s} to this new equation and calculate $r(\tilde{s})$ as well. **1**

Solving the equation, we get

$$\tilde{s} = \frac{4}{5} \frac{11}{18} = \frac{22}{45} \approx 0.489.$$
0.5

For $t = c$, this gives $\frac{1511}{3132} \approx 0.482$.

For $t = 1 - c$, this gives $\frac{1999}{4104} \approx 0.487$.

This shows that our preferred choice of t was good (the exact value is ≈ 0.489).

Therefore the minimal radius is approximately

$$r(s) \approx r(\tilde{s}) = \sqrt{-\frac{1}{4} \left(\frac{22}{45}\right)^4 + \left(\frac{22}{45}\right)^2 - \frac{31}{36} \frac{22}{45} + \frac{25}{81}} = \sqrt{\frac{921697}{8201250}} \approx 0.335.$$
0.5

For $t = c$ and $t = 1 - c$, this gives the same result to three figures.

Long problem 2.2: Clément-Desormes experiment

16

The Clément-Desormes experiment is a thermodynamics experiment used to determine the adiabatic index $\gamma = \frac{C_P}{C_V}$ of an ideal gas, where C_P and C_V are the heat capacities at constant pressure and constant volume, respectively. It consists of a container filled with the studied gas connected to a valve, a manometer (e.g. a mercury manometer) and a pump, see the figure. The three steps of the experiment consist of first increasing the pressure of the gas with the pump, then releasing the excess pressure through the valve and finally waiting for the gas to thermalize. In the following, we will consider the system that contains the n moles of gas remaining in the container after the pressure release (initially, there is more gas in the container than n moles).

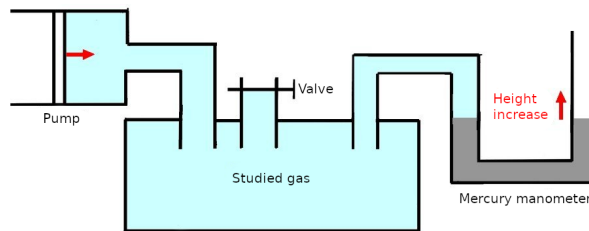

Figure 1: Schematic representation of the Clément-Desormes experiment.

Part A. Mercury manometers

2.25

A mercury manometer uses changes in the height of a column of mercury to determine the pressure of a gas, see the figure. Correspondingly, a millimeter of mercury, denoted mmHg, has become a unit of pressure. It is defined as the hydrostatic pressure generated by a column of mercury one millimeter high at a temperature of 0°C.

i. What is the hydrostatic pressure of a column of fluid of density ρ and height h ?

0.5

The hydrostatic pressure is given by $p = \rho gh$.

0.5

ii. How is 1 bar expressed in mmHg? The density of mercury at ambient pressure and temperature $T = 0^\circ\text{C}$ is $13.595 \text{ g} \cdot \text{cm}^{-3}$.

0.75

A bar is defined as $1 \text{ bar} = 1 \times 10^5 \text{ Pa}$, so $h = \frac{1 \times 10^5 \text{ Pa}}{\rho g} = \frac{1 \times 10^5 \text{ Pa}}{13.595 \text{ g/cm}^3 \cdot 9.80665 \text{ m} \cdot \text{s}^{-2}} = 750 \text{ mm}$. So, $1 \text{ bar} = 750 \text{ mmHg}$.

0.75

iii. Why is mercury particularly convenient to build such manometers as compared to other liquids?

1

The high density of mercury as compared to e.g. water (about 13.6 times higher) is convenient because the corresponding height change between two different pressures is significantly lower than with less dense liquids.

1

Part B. Pumping and releasing

2

One first uses the pump to increase the gas pressure to get from (P_0, V_0) to (P_A, V_{tot}) isothermally, where $P_A = P_0 + h_A = 780.31 \text{ mmHg}$ and V_{tot} is the total volume of the gas

container assumed to remain fixed for the rest of the experiment. The (partial) volume of the n moles at this stage is $V_A < V_{\text{tot}}$. So, at this point we have pressure and volume (P_A, V_A) for the n moles of gas considered. One then quickly opens the valve to let some of the gas escape and cancel the overpressure, and closes the valve directly after. The manometer tube is arbitrarily thin so the volume change necessary to modify the mercury height is negligible. We are only left with our n moles of gas with pressure and volume $(P_B, V_B) = (P_0, V_{\text{tot}})$. The ambient temperature is $T_0 = 12.5^\circ\text{C}$ and the ambient pressure is $P_0 = 766.50$ mmHg.

i. What type of thermodynamic process happens between the situations $A = (P_A, V_A)$ and $B = (P_B, V_B)$? Why? **0.5**

The process is adiabatic. 0.25

The reason is that we are considering a fast process such that no heat exchange occurs. 0.25

ii. For such a process, what equation relates the pressure and volume in situations A and B ? **1.5**

For an adiabatic process we have $PV^\gamma = \text{constant}$. 1

So, one finds $P_A V_A^\gamma = P_B V_B^\gamma$. 0.5

As long as the latter is given, full points are awarded.

Part C. Back to thermal equilibrium 2.5

After a while, the system reaches again thermal equilibrium with respect to the exterior. One ends up with pressure and volume $(P_C, V_C) = (P_0 + h_C, V_{\text{tot}})$, with $h_C = 3.61$ mmHg.

i. What type of thermodynamic process happens between the situations B and $C = (P_C, V_C)$? Why? **0.5**

The process is isochoric. 0.25

The reason is that the volume does not change between situations B and C . 0.25

ii. What is the temperature T_C in situation C ? **0.5**

As the system has thermalized with the exterior, the temperature is the ambient temperature, namely $T_C = 12.5^\circ\text{C}$. 0.5

iii. With what equation can one relate the pressure and volume in situations A and C ? **1.5**

We note that the temperature in case A is the same as the temperature in case C , since the initial pumping is an isothermic process. 0.5

With this, we can use the ideal gas law to write $P_A V_A = P_C V_C$. 1

Part D. Finding the adiabatic index 9.25

We can now consider the overall process to determine the adiabatic index γ from the previous measurements and results.

i. Draw schematically in a P - V diagram the thermodynamic processes acting on our system of n moles from step A to C . **1.25**

The diagram should schematically look like this:

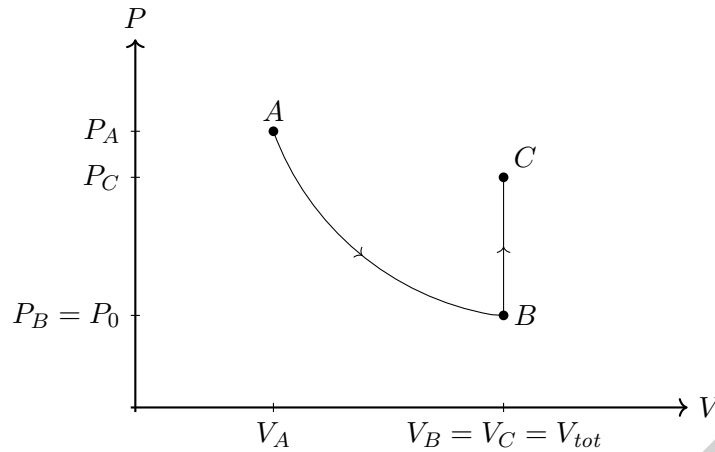

Figure D.1: P - V diagram of the experiment

The diagram axes are properly named as V and P (or p), respectively. 0.25

The ordering $P_A > P_C > P_B$ is respected. 0.25

The ordering $V_A < V_B = V_C$ is respected. 0.25

The adiabatic expansion has qualitatively the correct shape (a curved convex line). 0.25

The direction of the processes is shown and correct. 0.25

Remove 0.5 points if a line connects C and A (with a minimum of 0 points for the question).

ii. Use your equations from the previous parts to express $\frac{P_0+h_A}{P_0}$ as a function of (and including all) P_0, h_A, h_C and γ . 2

We recall from the previous parts that $P_A V_A^\gamma = P_B V_B^\gamma$ and $P_A V_A = P_C V_C$.

From $P_A V_A^\gamma = P_B V_B^\gamma$ we find

$$(P_0 + h_A) V_A^\gamma = P_0 V_{\text{tot}}^\gamma$$

which gives

$$\frac{P_0 + h_A}{P_0} = \left(\frac{V_{\text{tot}}}{V_A} \right)^\gamma.$$

1

From $P_A V_A = P_C V_C$ we get

$$\frac{V_{\text{tot}}}{V_A} = \frac{P_0 + h_A}{P_0 + h_C}$$

0.5

Combining both equations gives

$$\frac{P_0 + h_A}{P_0} = \left(\frac{P_0 + h_A}{P_0 + h_C} \right)^\gamma$$

. 0.5

iii. Noticing that $h_A \ll P_0$ and $h_C \ll P_0$ (\ll means “much smaller than”), simplify your expression for $\frac{P_0+h_A}{P_0+h_C}$.

Hint: for $x \ll 1$, one can approximate $(1+x)^\alpha \approx 1+\alpha x$.

Hint: you can neglect $\left(\frac{h_A}{P_0}\right)^2$, $\left(\frac{h_C}{P_0}\right)^2$, $\frac{h_A h_C}{P_0^2}$ and higher order terms. 2.5

We can start by rewriting the right-hand side of the previous answer in a way that we can use the given Taylor expansion:

$$\left(\frac{P_0+h_A}{P_0+h_C}\right)^\gamma = \left(1+\frac{h_A}{P_0}\right)^\gamma \left(1+\frac{h_C}{P_0}\right)^{-\gamma}$$

Applying the Taylor's expansion then gives (keeping only terms linear in $\frac{h_A}{P_0}$ and $\frac{h_C}{P_0}$)

$$\left(\frac{P_0+h_A}{P_0+h_C}\right)^\gamma \approx \left(1+\gamma\frac{h_A}{P_0}\right)\left(1-\gamma\frac{h_C}{P_0}\right) \approx 1+\gamma\frac{h_A-h_C}{P_0}.$$

We end up with

$$\frac{P_0+h_A}{P_0} = 1+\gamma\frac{h_A-h_C}{P_0}.$$

iv. Using your previous results, express the adiabatic index γ as a function of h_A and h_C . 1

Isolating γ we find

$$\gamma = \frac{h_A}{h_A-h_C}.$$

v. Compute numerically the adiabatic index γ from the given measurements. 1

Using the given numerical values for P_0 , P_0+h_A and h_C , one finds

$$\gamma = \frac{780.31 - 766.50}{780.31 - 766.50 - 3.61} \approx 1.35.$$

vi. From the equipartition theorem, it is possible to derive that $C_V = \frac{f}{2}R$ and $C_P = \frac{f+2}{2}R$, where f is the number of degrees of freedom allowed for the gas molecules. The gas studied here has $f = 5$ degrees of freedom. What is the relative difference between the theoretical and the experimental values of the adiabatic index γ ? 1

Using the definition of γ we find $\gamma = \frac{f+2}{f} = \frac{7}{5} = 1.4$. This gives a relative difference $\frac{\gamma_{th}-\gamma_{exp}}{\gamma_{th}} = 3.6\%$. 1

vii. What could be possible reasons for this difference? 0.5

If at least two of the following reasons is mentioned, or any other meaningful potential reason is mentioned, then the full points are obtained.

The discrepancy could come from: the statistical uncertainty in the measurements, a systematic uncertainty due to a wrong assumption (the process $A \rightarrow B$ might not be fully adiabatic, the change of volume due to the pressure changes in the manometer might not be negligible, the initial compression might not be fully isothermic, ...), etc. 0.5

Long problem 2.3: Mirror charges

16

A very common problem in electrostatics is to determine the electric potential of a system composed of point charges and conductors of various shapes. In this exercise, we will develop a trick, the so-called method of mirror charges or method of images, to greatly simplify such problems in cases with appropriate symmetry. We consider the SI unit system in this exercise.

Part A. Electric potential and conductors

2.25

In this first part, we will discuss Faraday cages.

i. Write down the electric potential V due to a point charge q as a function of the distance r from the charge.

0.25

The potential is given by $V(r) = \frac{1}{4\pi\epsilon_0} \frac{q}{r}$.

0.25

ii. Write down the electric potential V due to N point charges $q_i, i \in 1, 2, \dots, N$, as a function of the distances r_i from each charge q_i .

0.5

The total potential is given by the sum of the individual potentials: $V = \frac{1}{4\pi\epsilon_0} \sum_{i=1}^N \frac{q_i}{r_i}$.

0.5

iii. Consider the situation shown in Fig. B.1. What can you say about the electric potential on the surface of the grounded conducting material?

0.5

As we have a grounded conductor, the potential on the surface must vanish, so $V = 0$ on the conductor.

0.5

iv. During a storm, is it safer to stay in one's car or outside? Why? Argue using the answer to the previous question.

1

It is safer to stay in one's car, because the metallic hull of the car is a grounding conducting surface for which $V = 0$ holds such that its inside is protected against lightning.

1

Part B. Plane mirror charge

4.25

Consider again the situation illustrated in Fig. B.1. The goal of this part is to determine the electric potential at any point above the plane. For this, a trick can be used to simplify the situation considerably. The idea is to introduce an imaginary "mirror" charge in order to reproduce the boundary conditions set by the conducting material.

In electrostatics, if two physical systems have potentials with the same boundary conditions, then both situations are physically equivalent.

So, in order to determine the electric potential of this system, we would like to find another easier system to describe its potential.

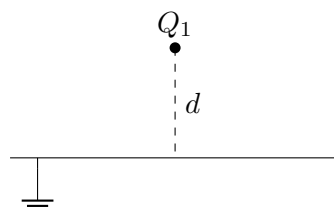

Figure B.1: Infinitely long grounded conductive plane and a charge Q_1 at a position $\vec{r}_1 = (x_1, y_1, z_1) = (0, 0, d)$.

i. What are the boundary conditions for the electrostatic potential V of this system? **0.25**

As seen in the previous part, the potential must satisfy $V = 0$ on the grounded conducting surface. 0.25

ii. Let us imagine a second physical system with the same charge Q_1 at the same position \vec{r}_1 as in Fig. B.1 but without the conducting plane. Our goal is to find a configuration with a second charge Q_2 at position \vec{r}_2 that has the same boundary conditions as in Fig. B.1. What should Q_2 and $\vec{r}_2 = (x_2, y_2, z_2)$ be for this to happen? Why? **1.5**

By symmetry, we can expect the mirror charge to lie at position $\vec{r}_2 = (0, 0, -d)$. 0.5

If the mirror charge lies at $(x_2, y_2, z_2) = (0, 0, -d)$ we can check that picking $Q_2 = -Q_1$ indeed satisfies the boundary conditions. 0.5

Indeed, this must be the case by symmetry. One could also check it explicitly using the result from Aii. 0.5

iii. Using your previous results, compute the electric potential $V(x, y, z)$ above the ground plane in the system of Fig. B.1 as a function of the coordinates (x, y, z) , the distance d and the charge Q_1 . The expression can be left as a sum of two terms, it does not have to be fully simplified. **1**

The resulting potential in the charge-plane conductor system must be the same as the charge-mirror charge system, so we obtain for $\vec{r} = (x, y, z)$

$$V(\vec{r}) = \frac{1}{4\pi\epsilon_0} \left[\frac{Q_1}{\sqrt{x^2 + y^2 + (z - d)^2}} - \frac{Q_1}{\sqrt{x^2 + y^2 + (z + d)^2}} \right].$$

1

The solution could be written in a different form as long as the potential is written explicitly as a function of the required quantities.

iv. Draw schematically the field lines of the system as shown in Fig. B.1, consisting of the point charge and ground plane system, assuming that $Q_1 > 0$ (in a separate sketch, not on the problem sheet). **1.5**

The drawing should qualitatively look like the upper half of the following image. The lower half should contain no field lines.

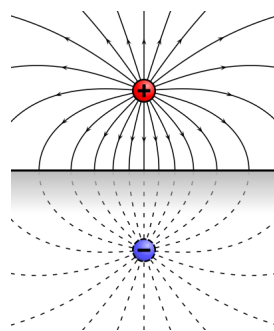

https://commons.wikimedia.org/wiki/File:VFpt_imagecharge_plane_horizontal_plusminus.svg

The field lines should flow from the positive charge to the conductor. 0.5

The field lines should stop at the level of the conductor. 0.5

The field lines at the level of the conductor should be perpendicular to its surface. 0.5

Part C. Right angle mirror charges 5.5

We will now consider more complex conductor geometries.

i. Let us consider the system shown in Fig. C.1. What is the number N of mirror charges needed to reproduce the conductor boundary conditions? What are their values Q_i and their positions $\vec{r}_i = (x_i, y_i, z_i)$ for $i = 1, 2, \dots, N$? Why?

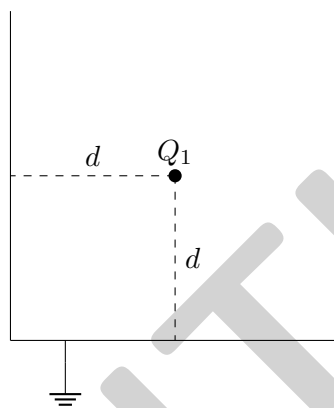

Figure C.1: Two infinitely long grounded half-plane conductors at a right-angle and a charge Q_1 at the position $\vec{r}_1 = (x_1, y_1, z_1) = (d, 0, d)$.

2.5

We want the potential to vanish on the conductor plates.

By symmetry considerations, we can convince ourselves that the mirror charges should lie at the positions $\vec{r}_2 = (-d, 0, d)$, $\vec{r}_3 = (-d, 0, -d)$ and $\vec{r}_4 = (d, 0, -d)$. 0.5

Similarly, we can expect to have $Q_2=Q_4$. 0.5

After some trial and error, one can notice that the choice $Q_2 = Q_4 = -Q_1$ and $Q_3 = Q_1$ leads to a vanishing potential on the conducting plates. 0.5

Indeed, by saying that r_i is the distance from the position \vec{r} to the charge i , we have

$$V(r) = \frac{1}{4\pi\epsilon_0} \left[\frac{Q_1}{r_1} - \frac{Q_1}{r_2} + \frac{Q_1}{r_3} - \frac{Q_1}{r_4} \right].$$

On the vertical plate, we have $r_1 = r_2$ and $r_3 = r_4$ such that indeed $V = 0$. On the horizontal plate we have $r_1 = r_4$ and $r_2 = r_3$ so we also have a vanishing potential. 1

A more explicit computation making less explicit use of symmetries, or a more implicit reasoning with the symmetries is fine as long as the reasoning is correct and indeed shows that the choice is the correct one.

ii. What is the corresponding potential $V(x, y, z)$ as a function of the coordinates (x, y, z) , the distance d and the charge Q_1 ? The expression can be left as a sum of N terms, it does not have to be fully simplified. 1

With the charges and positions from the previous question, we find the potential

$$V(x, y, z) = \frac{Q_1}{4\pi\epsilon_0} \left[\frac{1}{\sqrt{(x-d)^2 + y^2 + (z-d)^2}} - \frac{1}{\sqrt{(x+d)^2 + y^2 + (z-d)^2}} + \frac{1}{\sqrt{(x+d)^2 + y^2 + (z+d)^2}} - \frac{1}{\sqrt{(x-d)^2 + y^2 + (z+d)^2}} \right]. \tag{C.2}$$

The solution could be written in a different form as long as the potential is written explicitly as a function of the required quantities. 1

iii. Draw schematically the field lines of the charge-half-plane conductors system, assuming that $Q_1 < 0$ (in a separate sketch, not on the problem sheet). 2

The drawing should qualitatively look like the following image (do not consider the A, B, C, D arrows and the point X), but with the field lines stopping at the level of the two half-plane conductors.

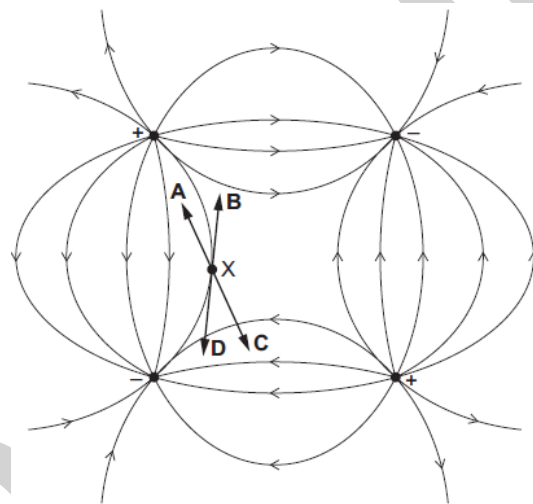

<https://physics-ref.blogspot.com/2019/01/the-diagram-shows-electric-field.html>

The field lines flow from positive to negative charges. 0.5

There is no straight line between the charge Q_1 and the charges Q_2 and Q_4 . 0.5

The field lines stop at the level of the conductors. 0.5

The overall shape is qualitatively similar to the picture above. 0.5

Part D. Circular mirror charges 4

It is also possible to define mirror charges for curved geometries.

i. Let us now consider the system shown in Fig. D.1. It turns out that only one mirror charge is needed to reproduce the corresponding boundary conditions. What is its value Q_2 and position $\vec{r}_2 = (x_2, y_2, z_2)$?

Hint: you are allowed to use without proof that a potential satisfying the appropriate boundary conditions at the positions $(r, 0, 0)$ and $(-r, 0, 0)$ satisfies the boundary conditions on the whole sphere.

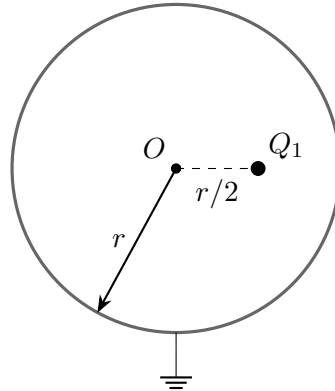

Figure D.1: Spherical grounded conductor of radius r with centre O at position $\vec{r}_0 = (0, 0, 0)$ and charge Q_1 at position $\vec{r}_1 = (x_1, y_1, z_1) = (r/2, 0, 0)$. We see here a slice at $y = 0$ of the sphere in the xz -plane.

2.5

By symmetry considerations, we expect the mirror charge to lie on the x -axis.

0.5

Using the hint, we consider the position $(r, 0, 0)$ where the potential should vanish. This gives us the condition

$$\frac{1}{4\pi\epsilon_0} \left[\frac{Q_1}{r/2} + \frac{Q_2}{|x_2 - r|} \right] = 0.$$

One can convince oneself qualitatively that having $x_2 - r < 0$ cannot lead to the appropriate boundary conditions on the full sphere. We then get

$$\frac{Q_2}{x_2 - r} = -\frac{2Q_1}{r}.$$

0.5

Considering now the position $(-r, 0, 0)$ we obtain the condition

$$\frac{1}{4\pi\epsilon_0} \left[\frac{Q_1}{3r/2} + \frac{Q_2}{x_2 + r} \right] = 0,$$

which gives

$$\frac{Q_2}{x_2 + r} = -\frac{2Q_1}{3r}.$$

0.5

With the first condition we have $Q_2 = -2Q_1 \frac{x_2 - r}{r}$, which we can insert in the second condition to obtain

$$\frac{2Q_1}{r} \frac{x_2 - r}{x_2 + r} = \frac{2Q_1}{3r}$$

and thus

$$x_2 - r = \frac{x_2 + r}{3},$$

which finally gives

$$x_2 = 2r.$$

The position of the mirror charge is thus $(x_2, y_2, z_2) = (2r, 0, 0)$. Inserting this back in the first conditions we also get $Q_2 = -2Q_1$.

1

A more explicit computation making less explicit use of symmetries, or a more implicit reasoning with the symmetries is fine as long as the reasoning is correct and indeed shows that the choice is the correct one.

ii. What is the corresponding potential $V(x, y, z)$ as a function of the coordinates (x, y, z) , the radius r and the charge Q_1 ? The expression can be left as a sum of two terms, it does not have to be fully simplified.

1.5

Using our previous results, we find

$$V(x, y, z) = \frac{Q_1}{4\pi\epsilon_0} \left[\frac{1}{\sqrt{(x - r/2)^2 + y^2 + z^2}} - \frac{2}{\sqrt{(x - 2r)^2 + y^2 + z^2}} \right].$$

1.5

The solution could be written in a different form as long as the potential is written explicitly as a function of the required quantities.